

GUANABA EXPERIENCE PRELIMINARY SITE PLANNING

PREPARED BY DESIGN EVOLUTION FOR GUANABA EXPERIENCE

April 21st, 2014

SITE PLAN
VISITORS CENTER AND RECEPTION AREA PLAN
CAMP ZONE 1 - 2WD SITES
CAMP ZONE 2 - 4WD SITES
CAMP ZONE 3 - 4WD SITES
PRESTIGE CAMPING SITE - 4WD
WATERFALL PICNIC AREA PLAN

DESIGN EVOLUTION
ARCHITECTURE + WEB DESIGN
ABN: 79 900 808 024

www.de-volution.com



de-volution.com

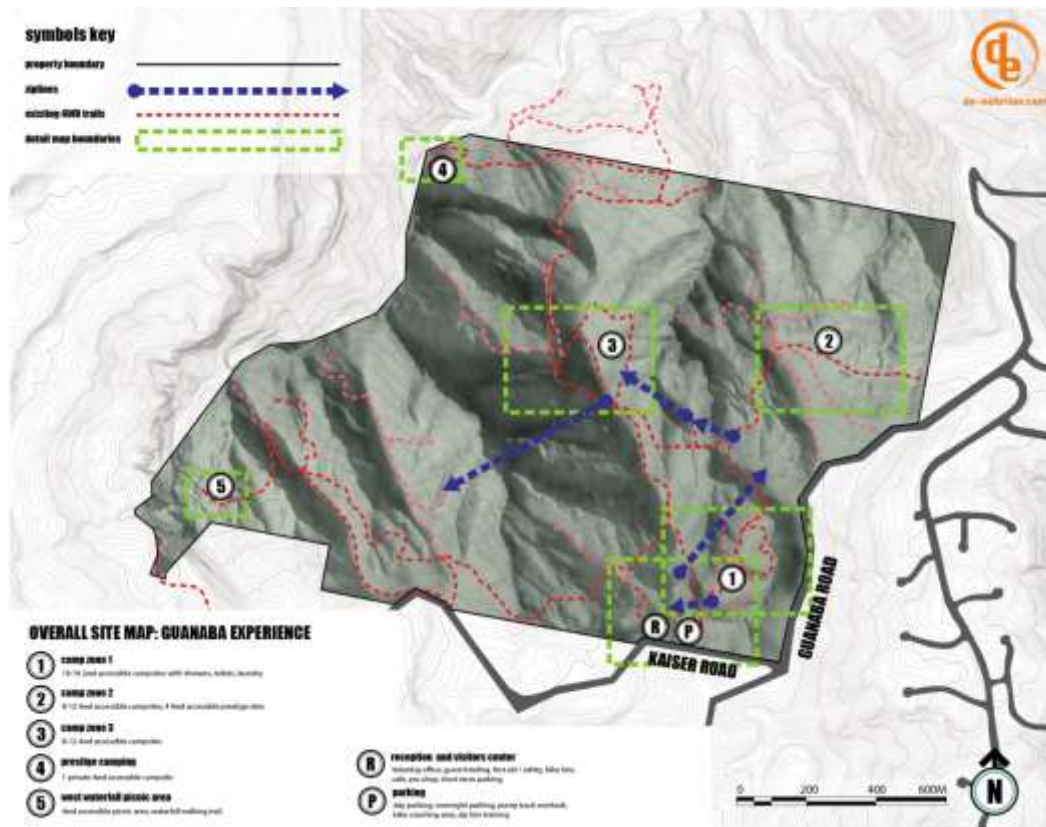

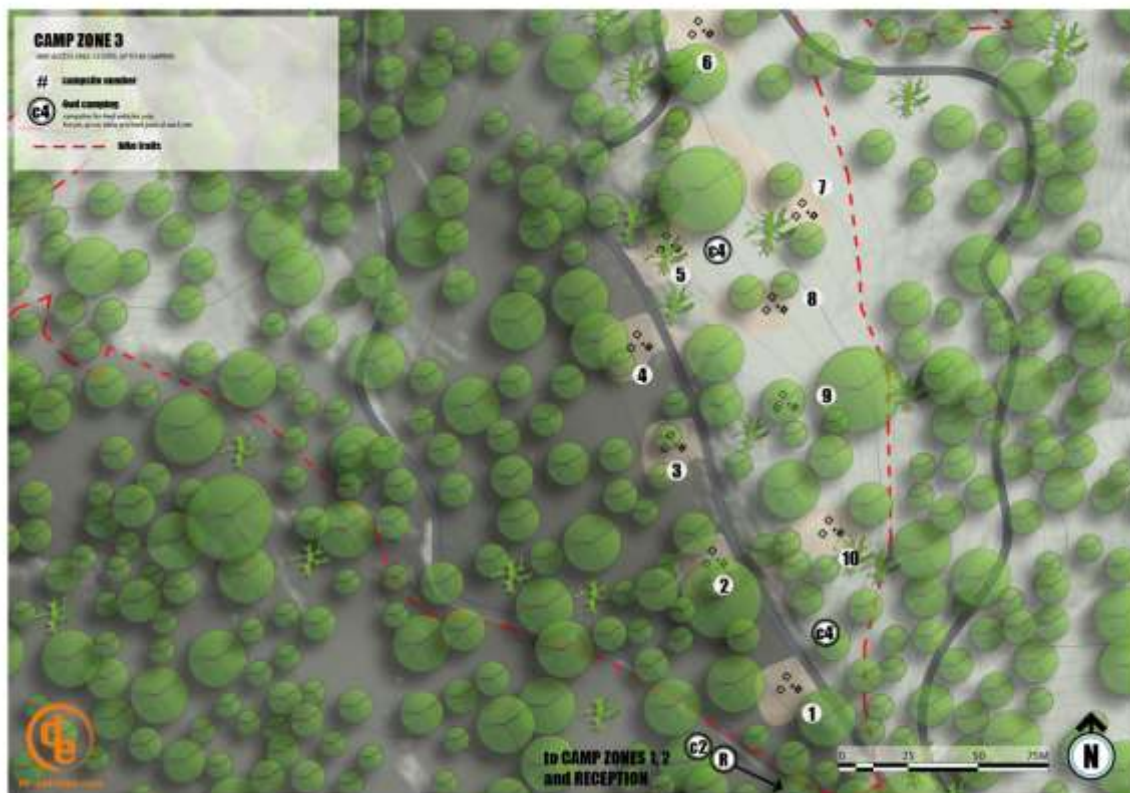
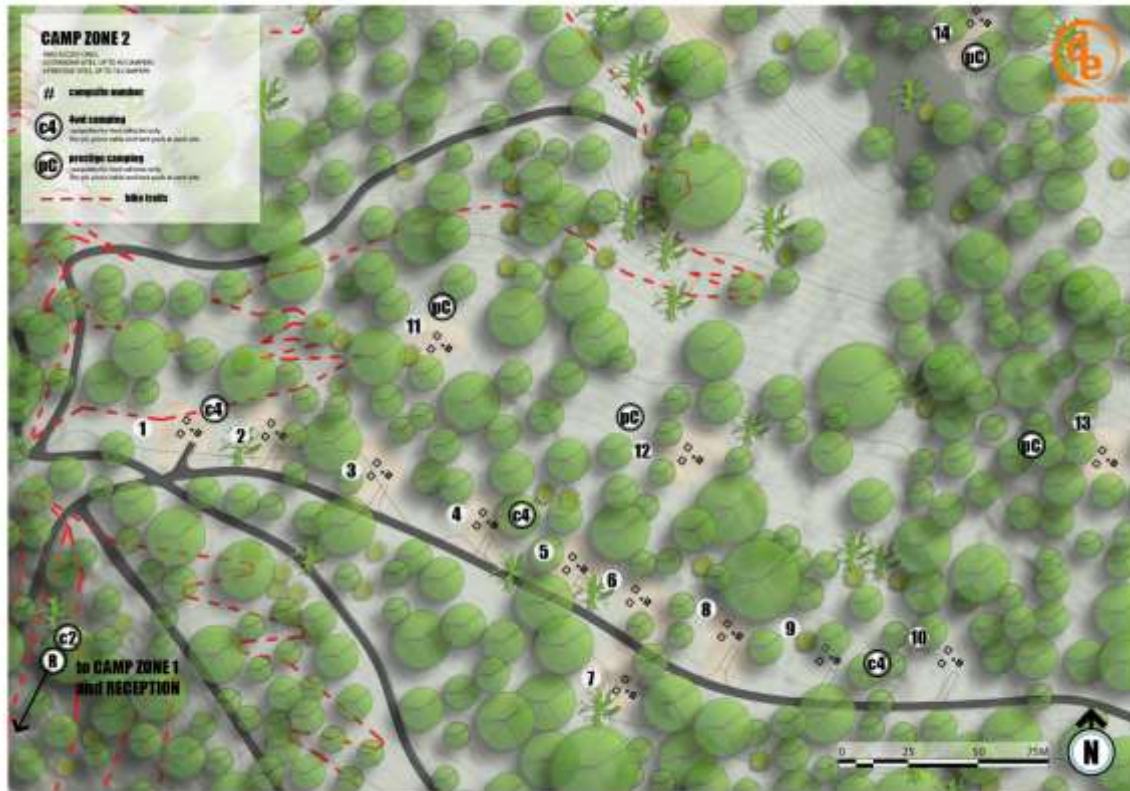

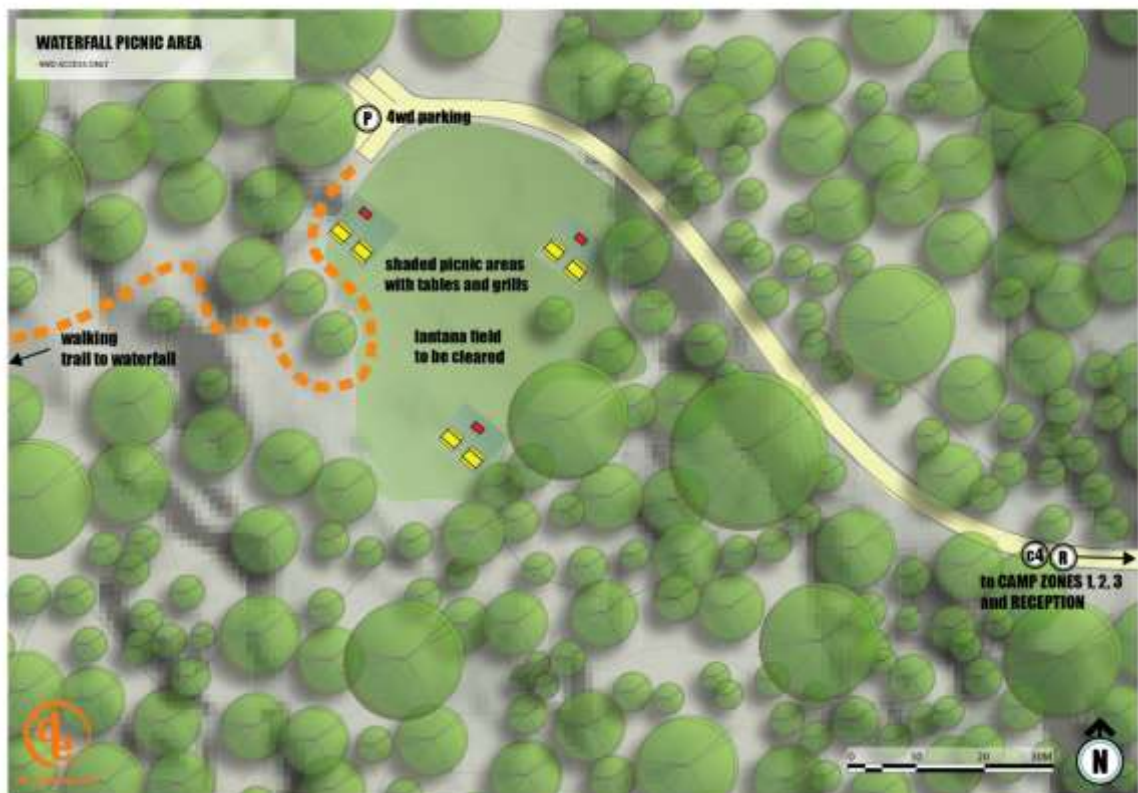

GUANABA EXPERIENCE PRELIMINARY VISITORS CENTER

PREPARED BY DESIGN EVOLUTION FOR GUANABA EXPERIENCE

March 24th, 2014

MAIN FLOOR PLAN
FURNITURE PLAN
ROOF PLAN
ELEVATIONS
SECTIONS



DESIGN EVOLUTION
ARCHITECTURE + WEB DESIGN
ABN: 79 900 806 024
www.de-volution.com

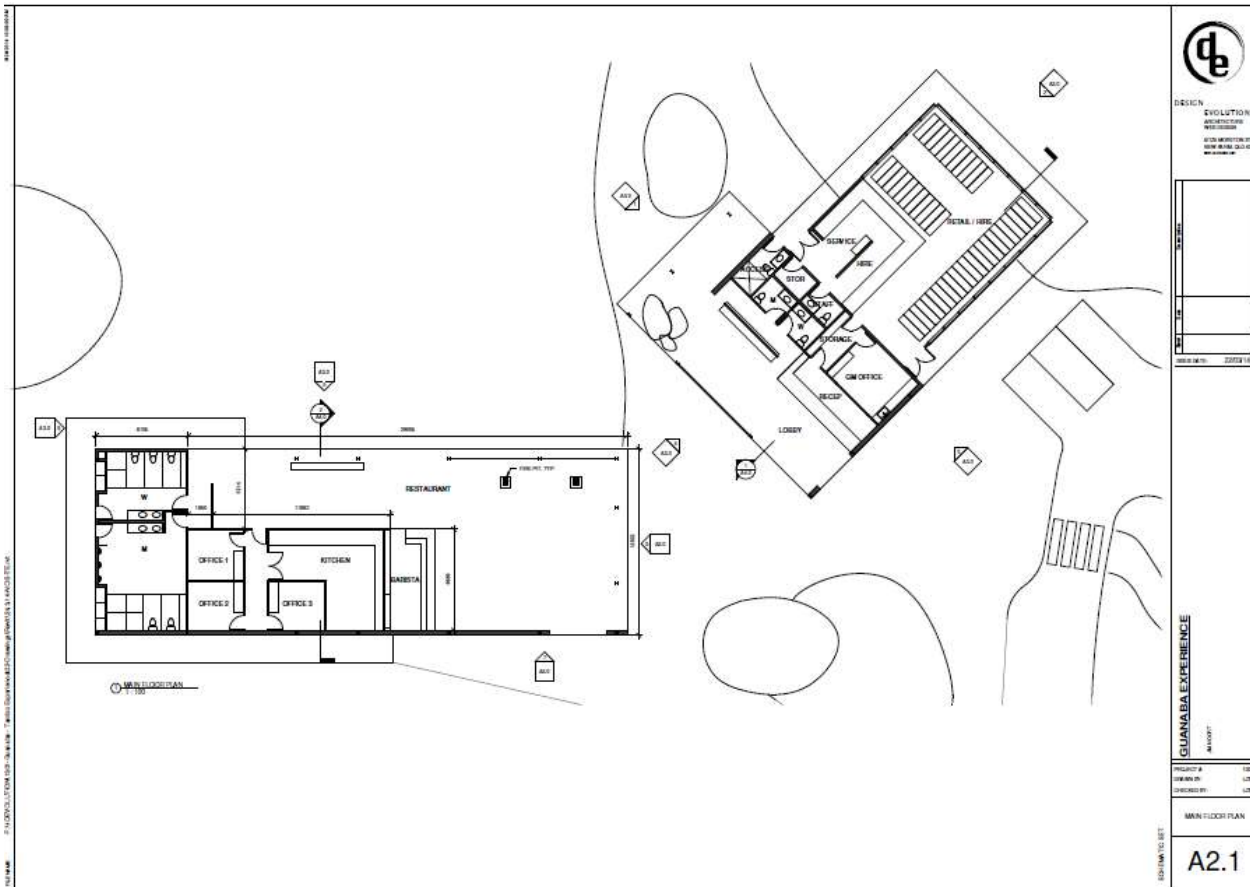

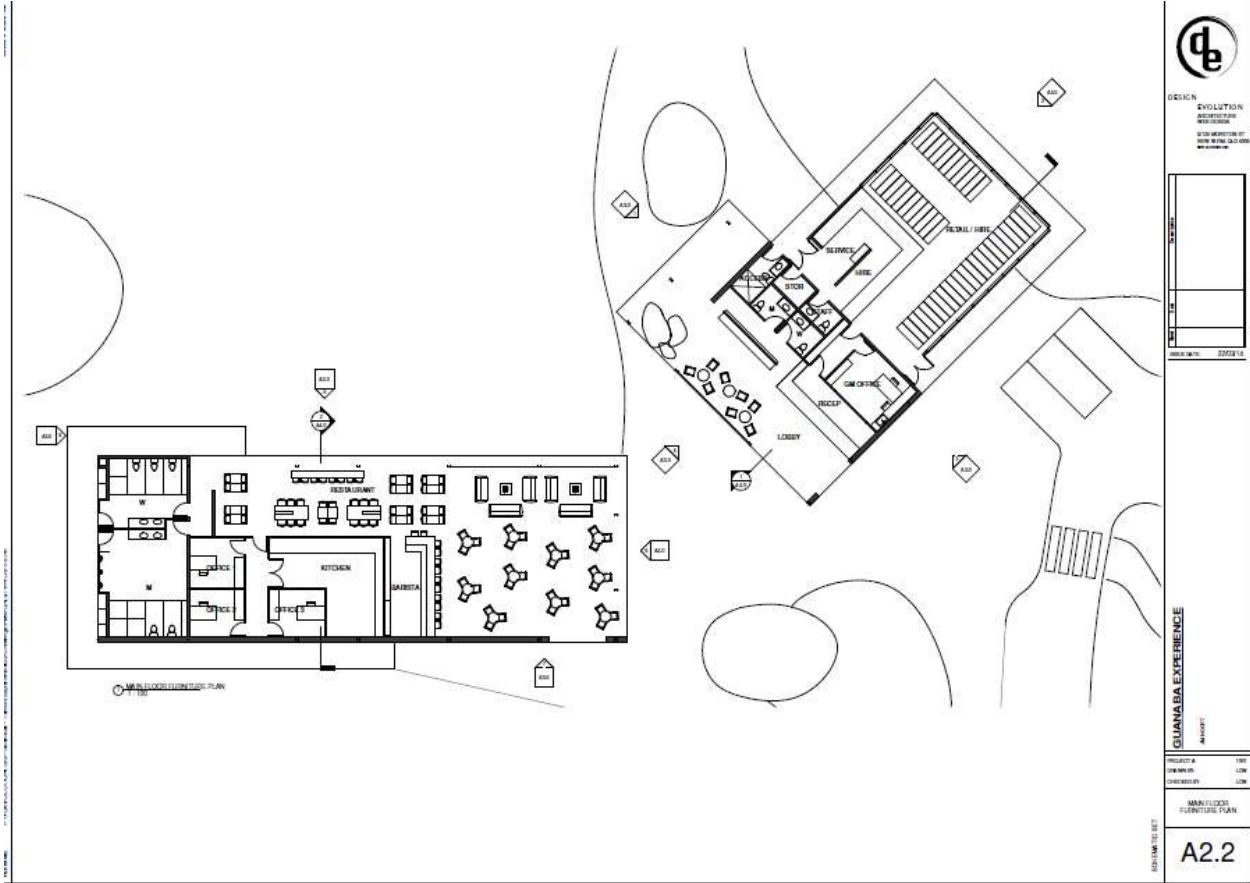

DESIGN
EVOLUTION
ARCHITECTURE
INTERIORS

PROJECT	GUANABA EXPERIENCE
CLIENT	ANANY
DATE	2023/11

PROJECT A	100
PROJECT B	100
PROJECT C	100

MANUSCRIPT
FLOOR PLAN
A2.2

EDUARD TOBIAS

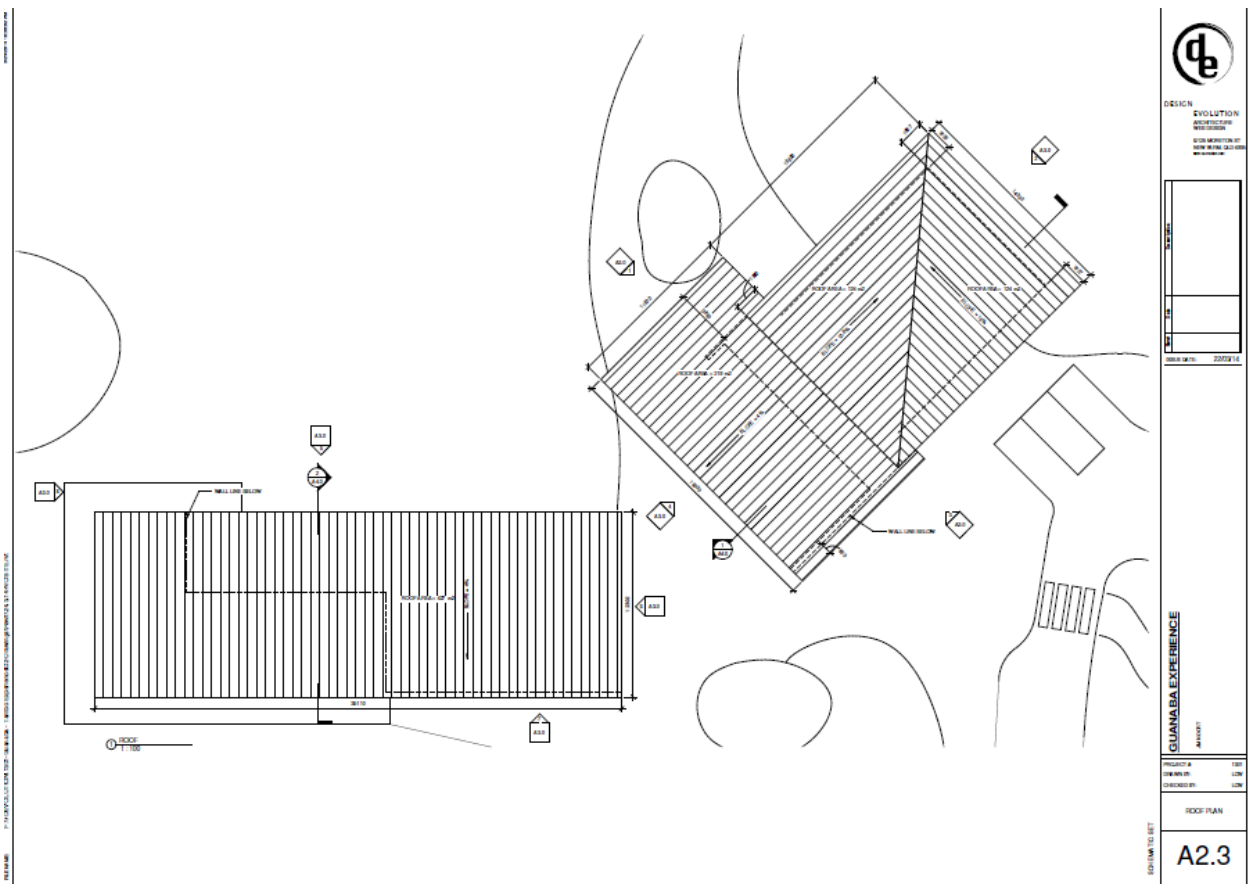

DESIGN
EVOLUTION
ARCHITECTURE
INTERIORS

PROJECT	GUANABA EXPERIENCE
CLIENT	ANANY
DATE	2023/11

PROJECT A	100
PROJECT B	100
PROJECT C	100

ROOF PLAN
A2.3

EDUARD TOBIAS

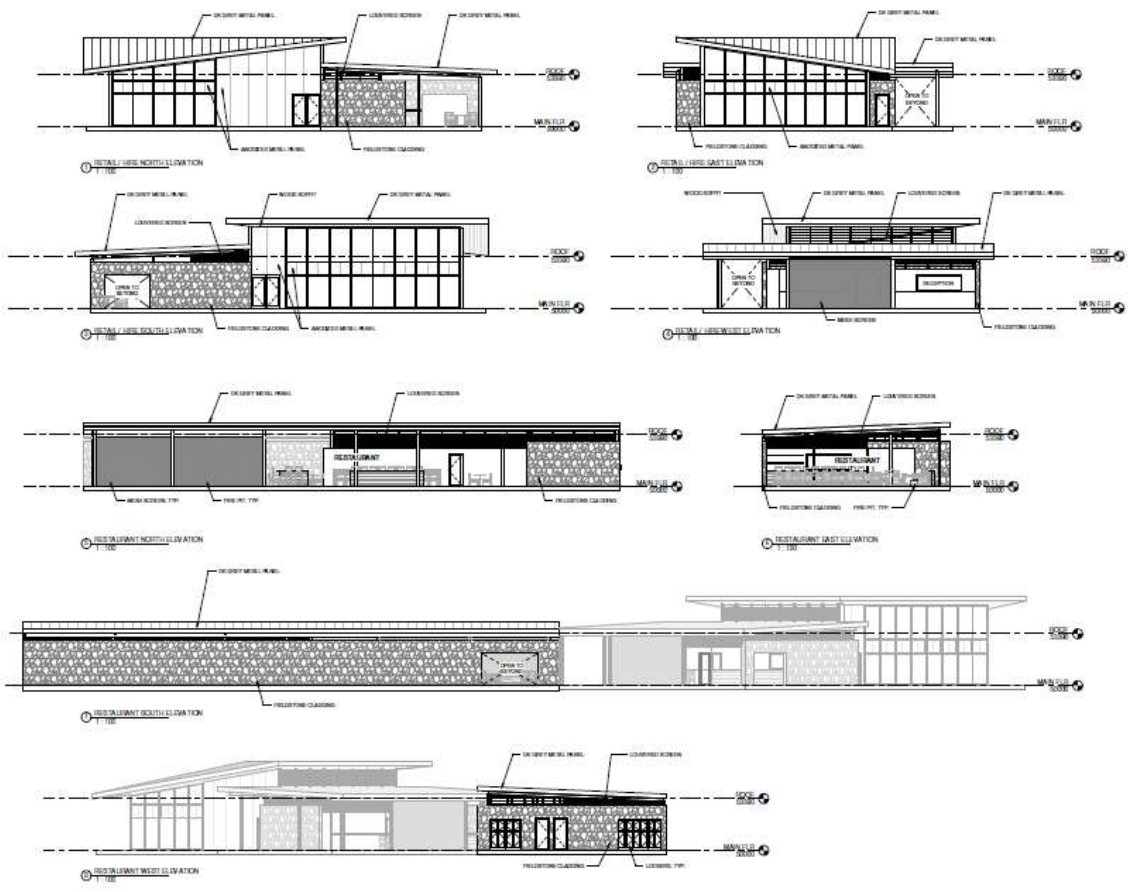

SCALE	
DATE	
PROJECT NO.	
REVISED DATE	

GUANABA EXPERIENCE

PROJECT # 100

PREPARED BY LHM

CHECKED BY LHM

DATE 02/20/18

ELEVATIONS

A3.0

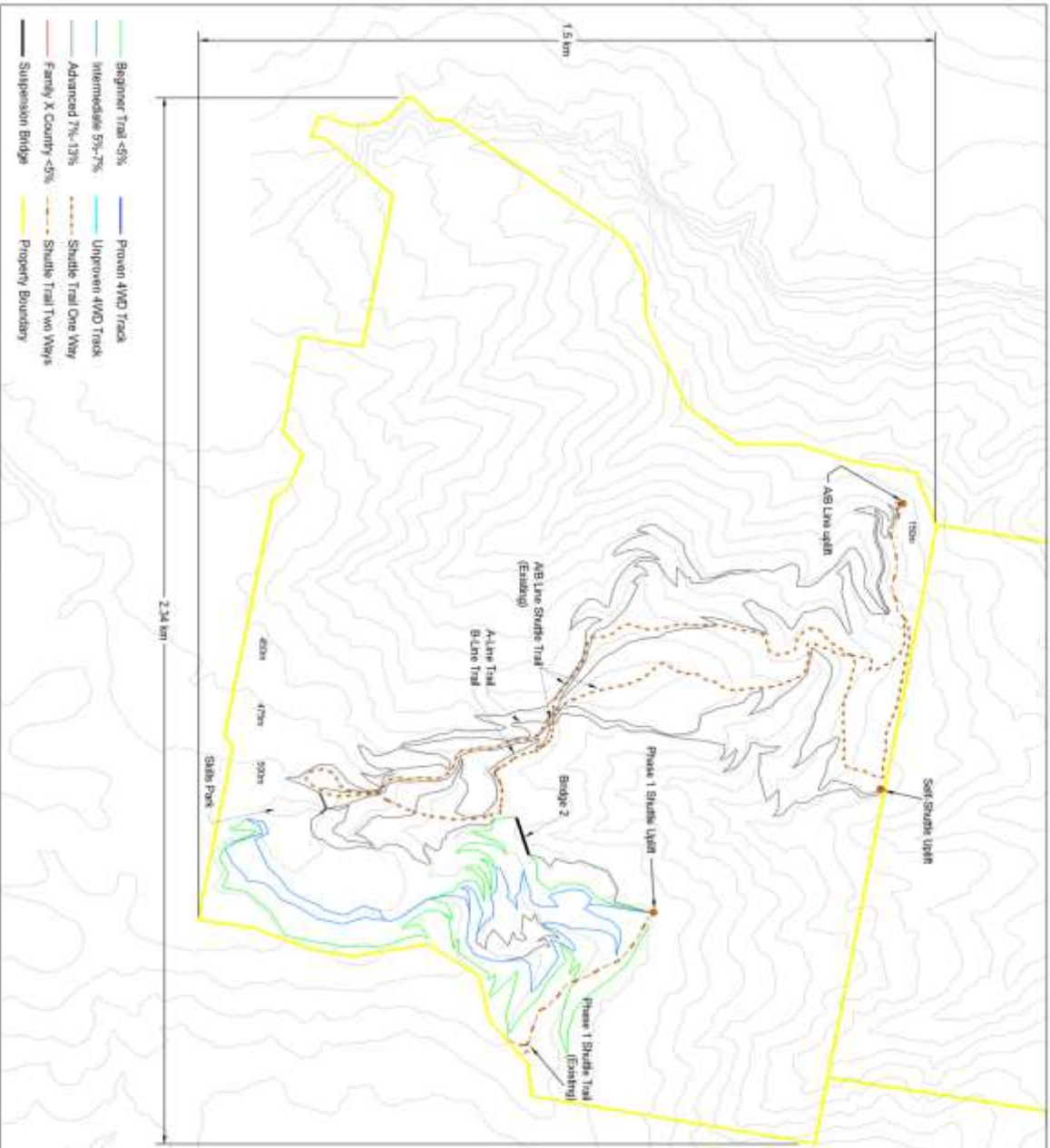

Drawn By : Jim Noort
 Date: 25/03/14
 Size: A3
 Phase 1
 Trails and Shuttles



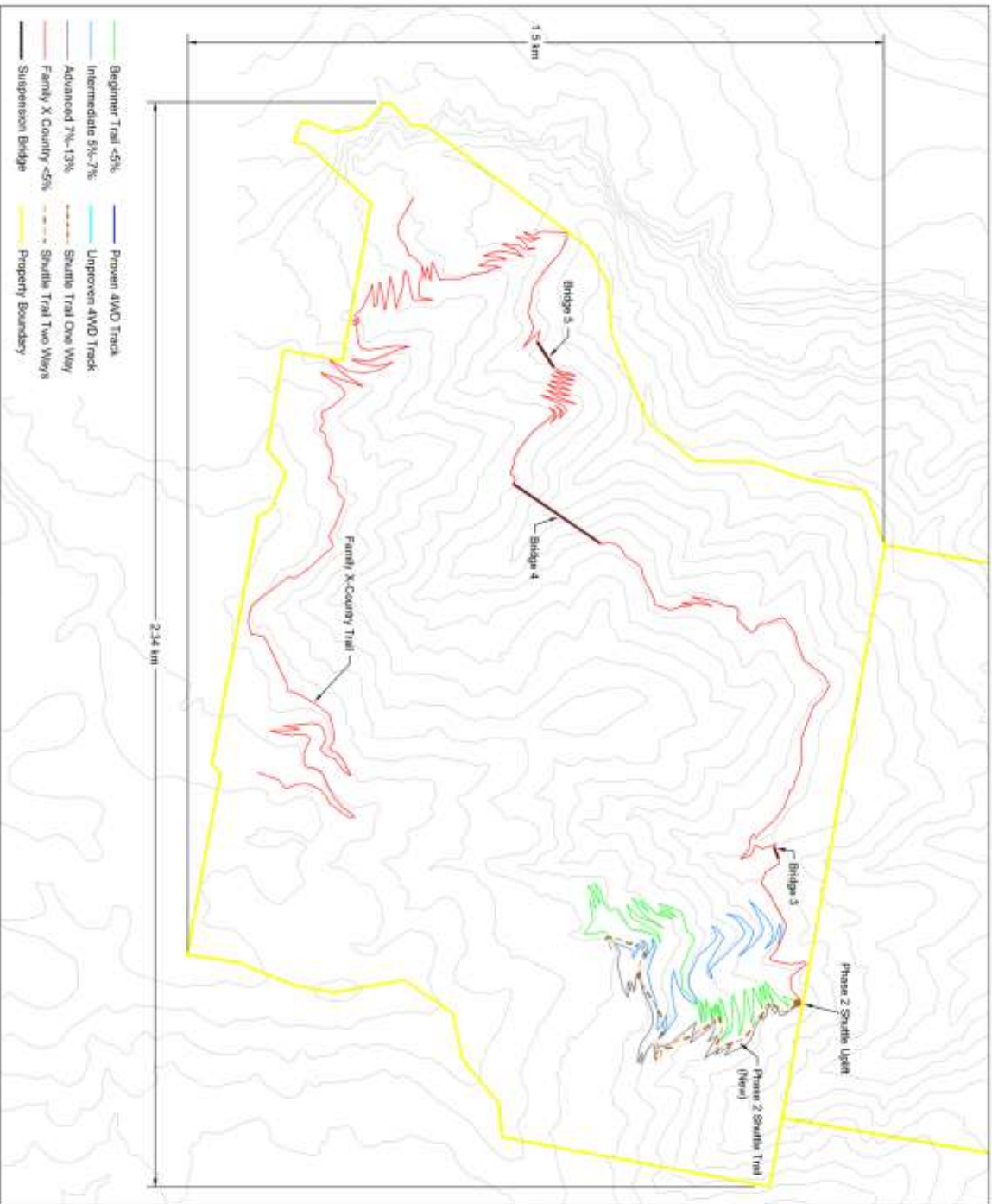

Drawn By : Jim Noort
 Date: 25/ 03/ 14
 Size: A3

Phase 2
 Trails and Shuttles



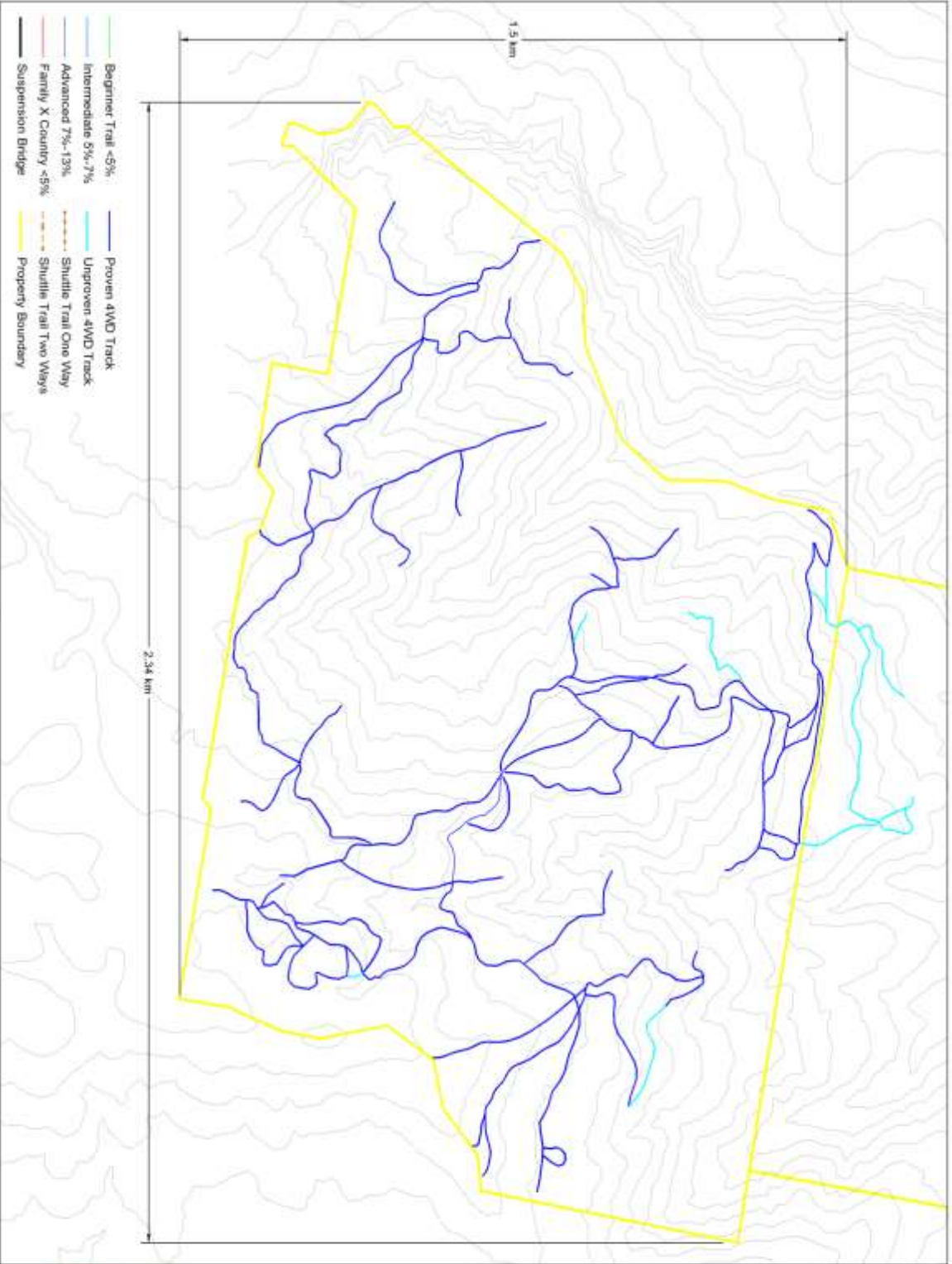

Drawn By : Jim Noort
 Date: 25/ 03/ 14
 Size: A3
 Existing 4WD Tracks



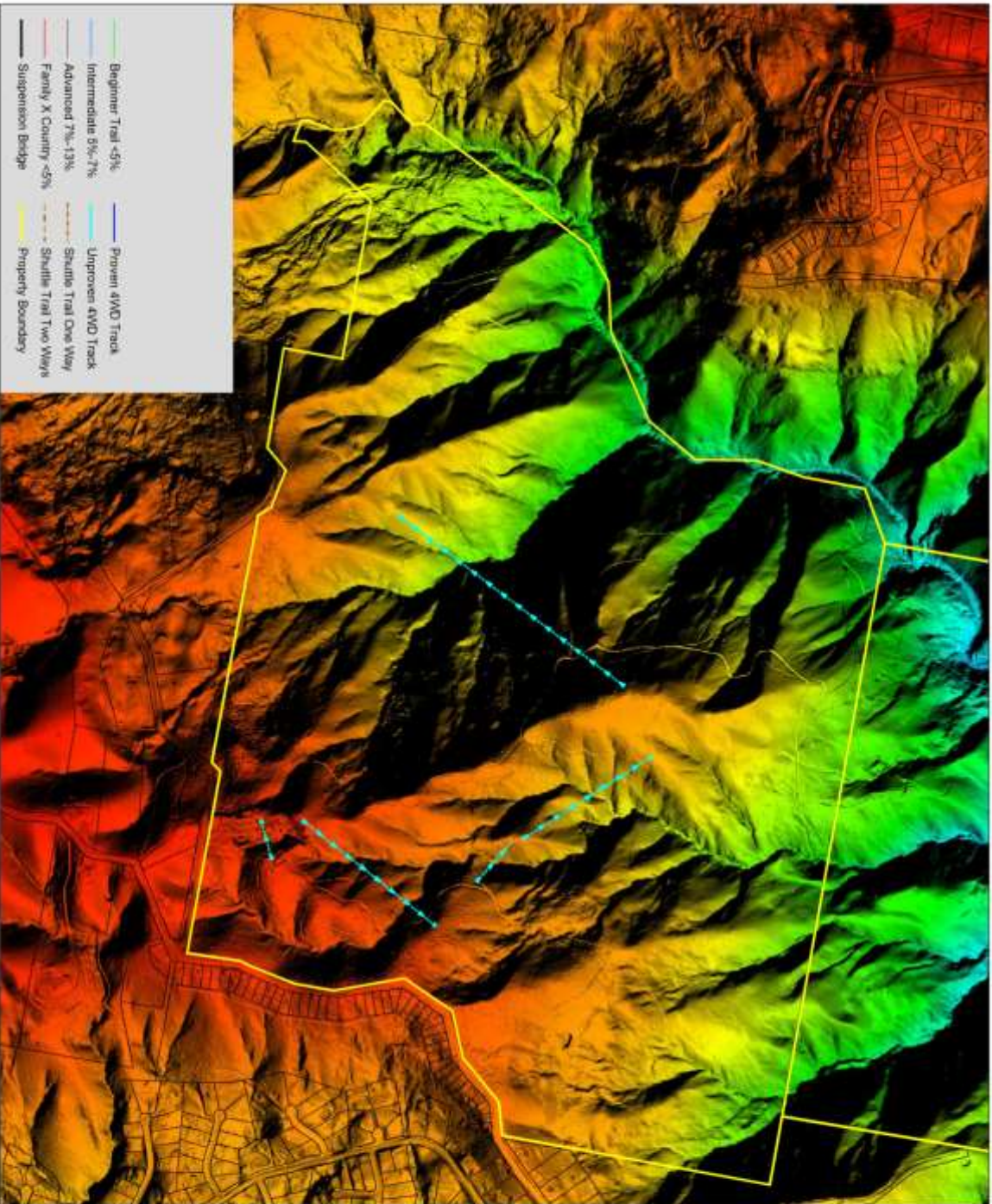

Drawn By : Jim Noort
 Date : 25/ 03/ 14
 Size : A3
 Zipline Course



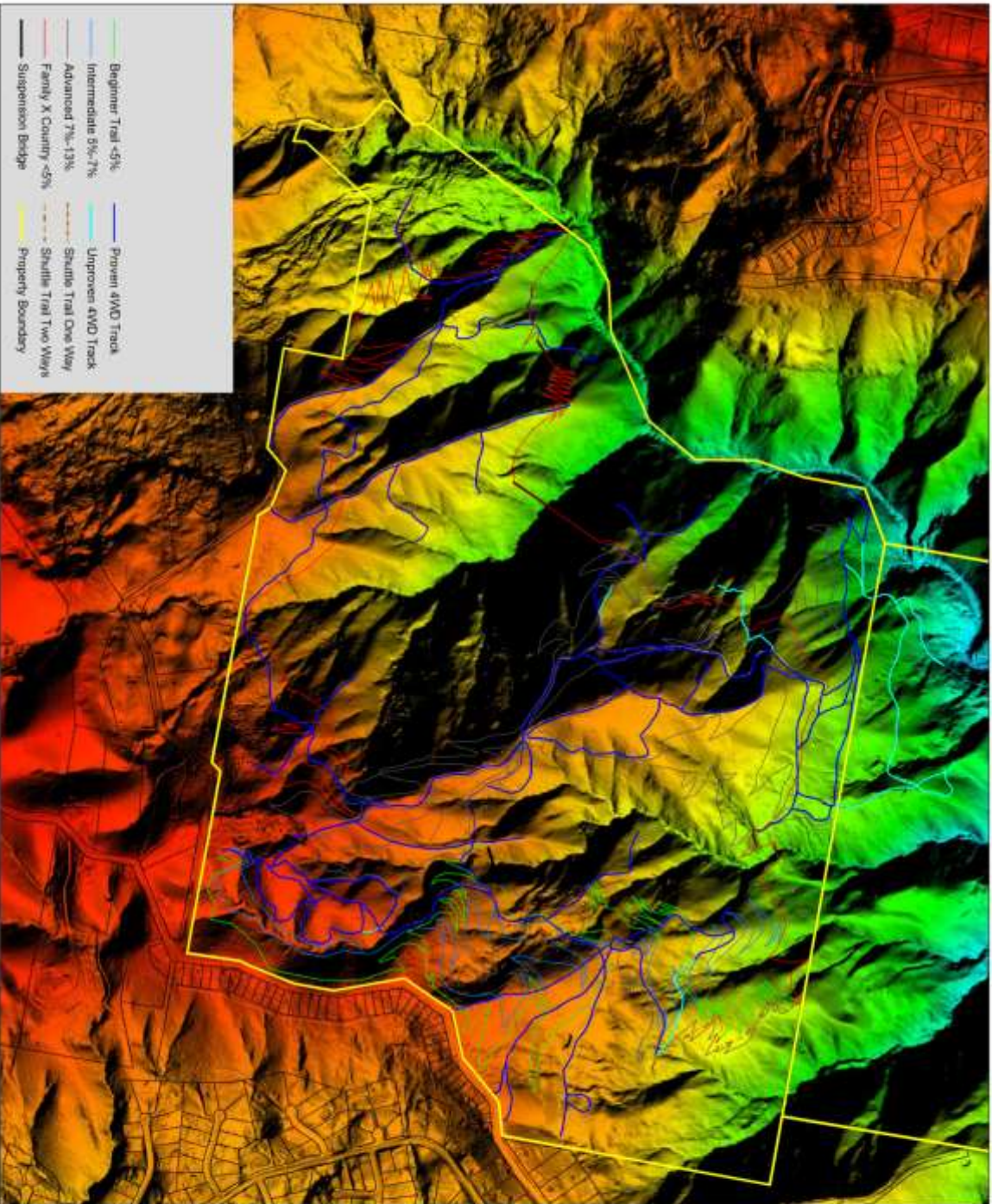

Drawn By : Jim Noort
 Date : 25/ 03/ 14
 Size: A3

Total Trail Network



Trails Plan Annotated Lot 3 on RP181081 amended in red by DNRM 13 February 2015 - Eldon Bottcher Architect Pty Ltd - FM1797 FM02 - 24 April 2014

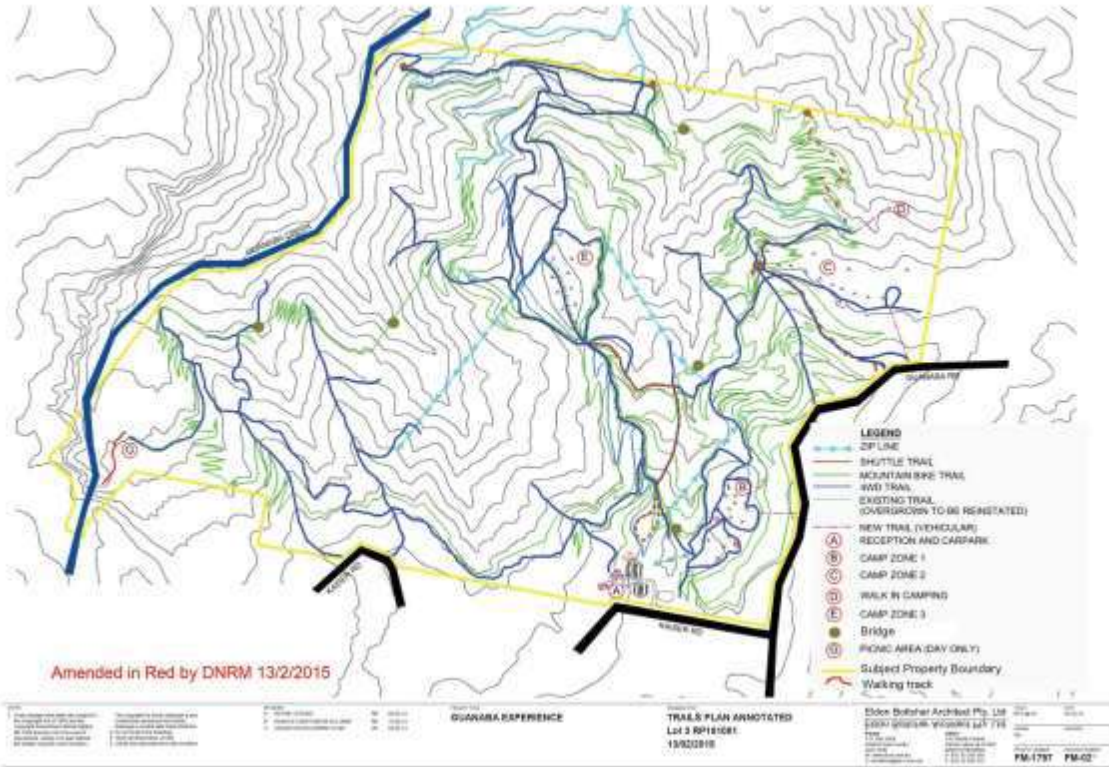



EXISTING TRACK (PROVEN)
 ———
EXISTING TRACK (UNPROVEN)
 - - - -

ADAPTED FROM:
 HBA/DAB GEOSPATIAL
 DESIGN EVOLUTION
 JIM NOORT
 KNOBEL CONSULTING
 PRECISE ENVIRONMENTAL
 ELDON BOTTICHER ARCHITECT
 DNRM

CLIENT:
 MOUNT TAMBORINE CAMPING AND
 ACTIVITIES PTY LTD

**BYRNS LARDNER
 ENVIRONMENTAL**

PROJECT:
 PROPOSED MCU DEVELOPMENT
 98 GUANABA ROAD,
 TAMBORINE MOUNTAIN
 LOT 3 RP181081

BYRNS LARDNER ENVIRONMENTAL
 P.O. BOX 538 SOUTHPORT QLD 4215
 E: info@byrnslardner.com.au
 T: 07 5593 9712

DRAWING: PROPERTY VEGETATION MANAGEMENT PLAN			
DATE:	MAY 2014	DRAWN:	MJ
PROJECT NO.:	TAM03	SCALE:	1:7500 @ A3
DRAWING NO.:	GUA03_PVMP	ISSUE:	A
		SHEET NO.:	1 OF 1